

No part of this product may be reproduced in any form or by any electronic or mechanical means, including information storage and retrieval systems, without written permission from the IB.

Additionally, the license tied with this product prohibits commercial use of any selected files or extracts from this product. Use by third parties, including but not limited to publishers, private teachers, tutoring or study services, preparatory schools, vendors operating curriculum mapping services or teacher resource digital platforms and app developers, is not permitted and is subject to the IB's prior written consent via a license. More information on how to request a license can be obtained from <http://www.ibo.org/contact-the-ib/media-inquiries/for-publishers/guidance-for-third-party-publishers-and-providers/how-to-apply-for-a-license>.

Aucune partie de ce produit ne peut être reproduite sous quelque forme ni par quelque moyen que ce soit, électronique ou mécanique, y compris des systèmes de stockage et de récupération d'informations, sans l'autorisation écrite de l'IB.

De plus, la licence associée à ce produit interdit toute utilisation commerciale de tout fichier ou extrait sélectionné dans ce produit. L'utilisation par des tiers, y compris, sans toutefois s'y limiter, des éditeurs, des professeurs particuliers, des services de tutorat ou d'aide aux études, des établissements de préparation à l'enseignement supérieur, des fournisseurs de services de planification des programmes d'études, des gestionnaires de plateformes pédagogiques en ligne, et des développeurs d'applications, n'est pas autorisée et est soumise au consentement écrit préalable de l'IB par l'intermédiaire d'une licence. Pour plus d'informations sur la procédure à suivre pour demander une licence, rendez-vous à l'adresse <http://www.ibo.org/fr/contact-the-ib/media-inquiries/for-publishers/guidance-for-third-party-publishers-and-providers/how-to-apply-for-a-license>.

No se podrá reproducir ninguna parte de este producto de ninguna forma ni por ningún medio electrónico o mecánico, incluidos los sistemas de almacenamiento y recuperación de información, sin que medie la autorización escrita del IB.

Además, la licencia vinculada a este producto prohíbe el uso con fines comerciales de todo archivo o fragmento seleccionado de este producto. El uso por parte de terceros —lo que incluye, a título enunciativo, editoriales, profesores particulares, servicios de apoyo académico o ayuda para el estudio, colegios preparatorios, desarrolladores de aplicaciones y entidades que presten servicios de planificación curricular u ofrezcan recursos para docentes mediante plataformas digitales— no está permitido y estará sujeto al otorgamiento previo de una licencia escrita por parte del IB. En este enlace encontrará más información sobre cómo solicitar una licencia: <http://www.ibo.org/es/contact-the-ib/media-inquiries/for-publishers/guidance-for-third-party-publishers-and-providers/how-to-apply-for-a-license>.

Physics
Higher level
Paper 1

Friday 17 May 2019 (afternoon)

1 hour

Instructions to candidates

- Do not open this examination paper until instructed to do so.
- Answer all the questions.
- For each question, choose the answer you consider to be the best and indicate your choice on the answer sheet provided.
- A clean copy of the **physics data booklet** is required for this paper.
- The maximum mark for this examination paper is **[40 marks]**.

1. A student is verifying the equation

$$x = \frac{2\lambda Y}{z}$$

The percentage uncertainties are:

Quantity	Uncertainty
λ	$\pm 10\%$
Y	$\pm 0.05\%$
z	$\pm 5\%$

What is the percentage uncertainty in x ?

- A. 5%
 - B. 15%
 - C. 25%
 - D. 30%
2. A student models the relationship between the pressure p of a gas and its temperature T as $p = x + yT$.

The units of p are pascal and the units of T are kelvin. What are the fundamental SI units of x and y ?

	x	y
A.	$\text{kg m}^{-1} \text{s}^{-2}$	$\text{kg m}^{-1} \text{s}^{-2} \text{K}^{-1}$
B.	$\text{kg m}^{-1} \text{s}^{-2}$	K^{-1}
C.	K	$\text{kg m}^{-1} \text{s}^{-2} \text{K}^{-1}$
D.	K	K^{-1}

3. A sky diver is falling at terminal speed when she opens her parachute. What are the direction of her velocity vector and the direction of her acceleration vector before she reaches the new terminal speed?

	Direction of velocity vector	Direction of acceleration vector
A.	upwards	upwards
B.	upwards	downwards
C.	downwards	upwards
D.	downwards	downwards

4. A sports car is accelerated from 0 to 100 km per hour in 3 s. What is the acceleration of the car?

- A. 0.1 *g*
- B. 0.3 *g*
- C. 0.9 *g*
- D. 3 *g*

5. A girl throws an object horizontally at time $t = 0$. Air resistance can be ignored. At $t = 0.50$ s the object travels horizontally a distance x in metres while it falls vertically through a distance y in metres.

What is the initial velocity of the object and the vertical distance fallen at $t = 1.0$ s?

	Initial velocity / ms^{-1}	Vertical distance fallen / m
A.	x	$2y$
B.	x	$4y$
C.	$2x$	$2y$
D.	$2x$	$4y$

Turn over

6. An object of mass m is sliding down a ramp at constant speed. During the motion it travels a distance x along the ramp and falls through a vertical distance h . The coefficient of dynamic friction between the ramp and the object is μ . What is the total energy transferred into thermal energy when the object travels distance x ?

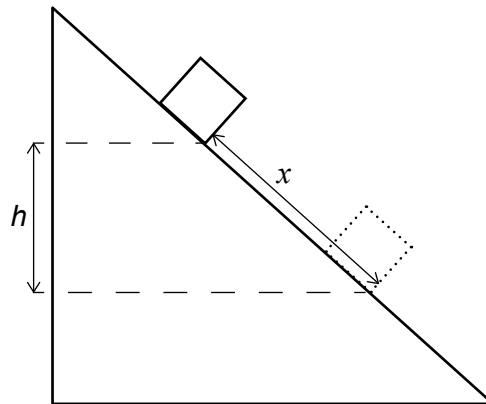

- A. mgh
B. mgx
C. μmgh
D. μmgx
7. A waiter carrying a tray is accelerating to the right as shown in the image. What is the free-body diagram of the forces acting on the tray?

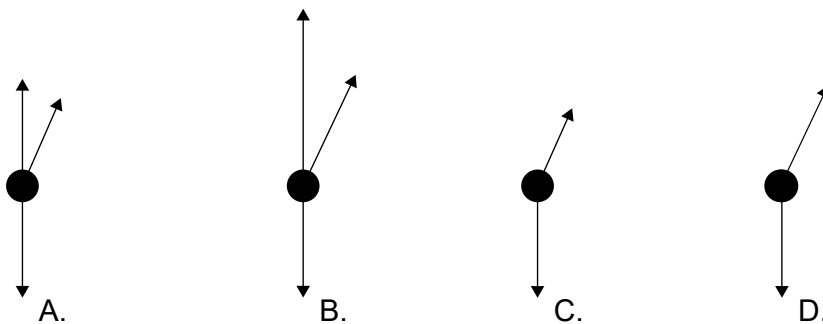

8. Energy is transferred to water in a flask at a rate P . The water reaches boiling point and then P is increased. What are the changes to the temperature of the water and to the rate of vaporization of the water after the change?

	Temperature	Rate of vaporization
A.	increases	stays the same
B.	increases	increases
C.	stays the same	stays the same
D.	stays the same	increases

9. An insulated tube is filled with a large number n of lead spheres, each of mass m . The tube is inverted s times so that the spheres completely fall through an average distance L each time. The temperature of the spheres is measured before and after the inversions and the resultant change in temperature is ΔT .

What is the specific heat capacity of lead?

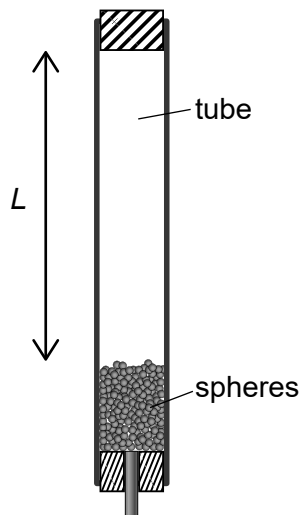

- A. $\frac{sgL}{nm\Delta T}$
- B. $\frac{sgL}{\Delta T}$
- C. $\frac{sgL}{n\Delta T}$
- D. $\frac{gL}{m\Delta T}$

Turn over

10. A gas storage tank of fixed volume V contains N molecules of an ideal gas at temperature T . The pressure at kelvin temperature T is 20 MPa. $\frac{N}{4}$ molecules are removed and the temperature changed to $2T$. What is the new pressure of the gas?
- A. 10 MPa
 - B. 15 MPa
 - C. 30 MPa
 - D. 40 MPa
11. A particle performs simple harmonic motion (shm). What is the phase difference between the displacement and the acceleration of the particle?
- A. 0
 - B. $\frac{\pi}{2}$
 - C. π
 - D. $\frac{3\pi}{2}$

12. Which graph shows the variation with time t of the kinetic energy (KE) of an object undergoing simple harmonic motion (shm) of period T ?

A.

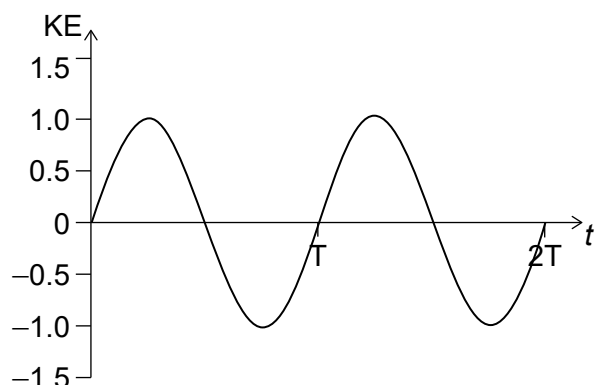

B.

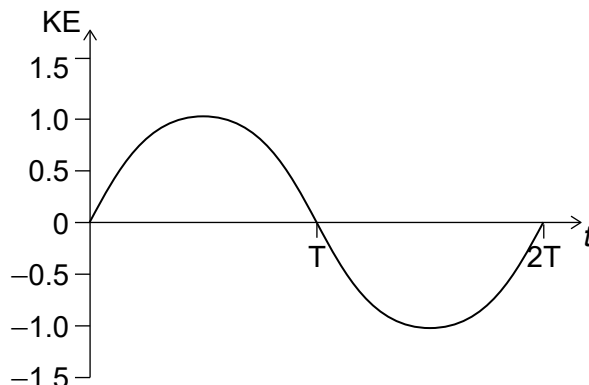

C.

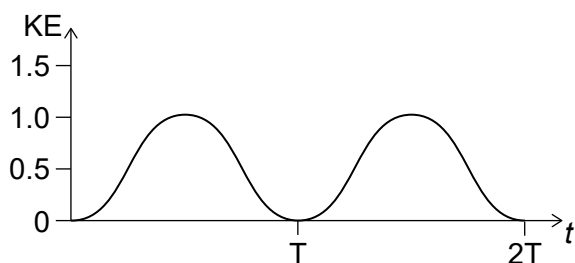

D.

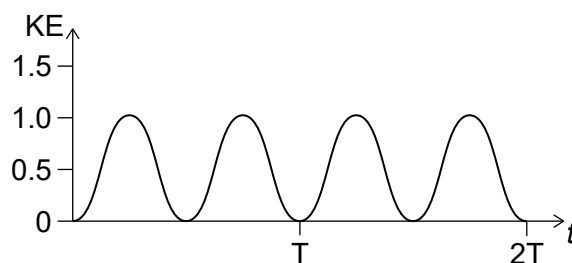

13. A glass block of refractive index 1.5 is immersed in a tank filled with a liquid of higher refractive index. Light is incident on the base of the glass block. Which is the correct diagram for rays incident on the glass block at an angle greater than the critical angle?

A.

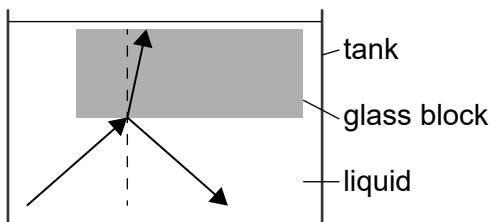

B.

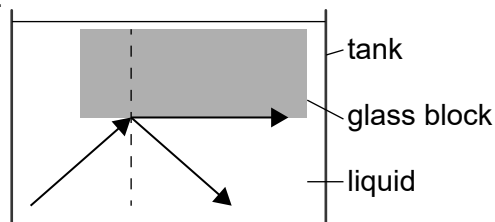

C.

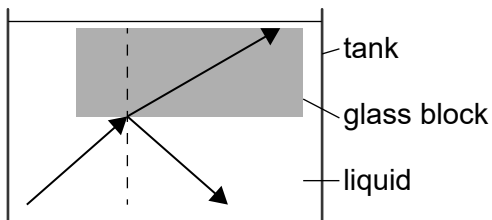

D.

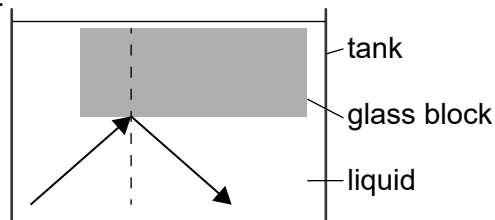

Turn over

14. In an experiment to determine the speed of sound in air, a tube that is open at the top is filled with water and a vibrating tuning fork is held over the tube as the water is released through a valve.

An increase in intensity in the sound is heard for the first time when the air column length is x . The next increase is heard when the air column length is y .

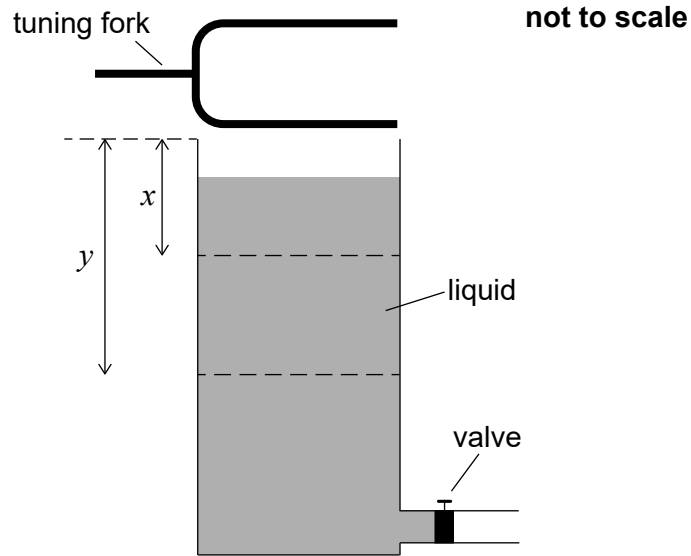

Which expressions are approximately correct for the wavelength of the sound?

- I. $4x$
 - II. $4y$
 - III. $\frac{4y}{3}$
- A. I and II
 - B. I and III
 - C. II and III
 - D. I, II and III

15. Charge flows through a liquid. The charge flow is made up of positive and negative ions. In one second 0.10 C of negative ions flow in one direction and 0.10 C of positive ions flow in the opposite direction.

What is the magnitude of the electric current flowing through the liquid?

- A. 0 A
 B. 0.05 A
 C. 0.10 A
 D. 0.20 A
16. Two parallel plates are a distance apart with a potential difference between them. A point charge moves from the negatively charged plate to the positively charged plate. The charge gains kinetic energy W . The distance between the plates is doubled and the potential difference between them is halved. What is the kinetic energy gained by an identical charge moving between these plates?
- A. $\frac{W}{2}$
 B. W
 C. $2W$
 D. $4W$
17. A resistor of resistance R is connected to a fully charged cell of negligible internal resistance. A constant power P is dissipated in the resistor and the cell discharges in time t . An identical cell is connected in series with two identical resistors each of resistance R .

What is the power dissipated in each resistor and the time taken to discharge the cell?

	Power dissipated in each resistor	Time taken to discharge the cell
A.	$\frac{P}{4}$	$\frac{t}{2}$
B.	$\frac{P}{4}$	$2t$
C.	$\frac{P}{2}$	$\frac{t}{2}$
D.	$\frac{P}{2}$	$2t$

Turn over

18. Two currents of 3A and 1A are established in the same direction through two parallel straight wires R and S.

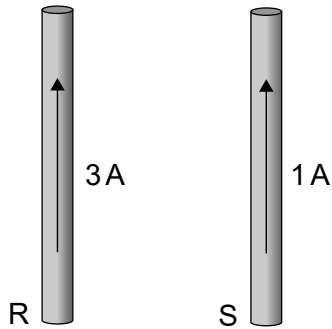

What is correct about the magnetic forces acting on each wire?

- A. Both wires exert equal magnitude attractive forces on each other.
 - B. Both wires exert equal magnitude repulsive forces on each other.
 - C. Wire R exerts a larger magnitude attractive force on wire S.
 - D. Wire R exerts a larger magnitude repulsive force on wire S.
19. A horizontal electrical cable carries a steady current out of the page. The Earth's magnetic field exerts a force on the cable.

Which arrow shows the direction of the force on the cable due to the Earth's magnetic field?

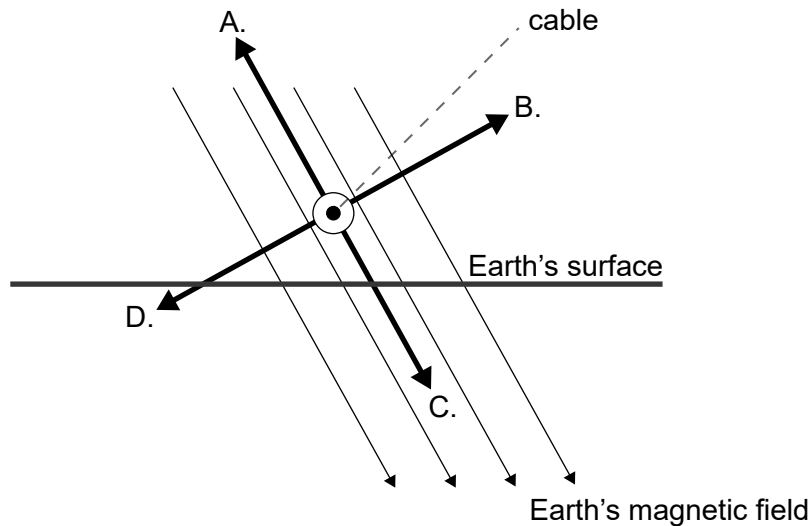

20. Satellite X orbits a planet with orbital radius R . Satellite Y orbits the same planet with orbital radius $2R$. Satellites X and Y have the same mass.

What is the ratio $\frac{\text{centripetal acceleration of X}}{\text{centripetal acceleration of Y}}$?

- A. $\frac{1}{4}$
- B. $\frac{1}{2}$
- C. 2
- D. 4

21. A motorcyclist is cornering on a curved race track.

Which combination of changes of banking angle θ and coefficient of friction μ between the tyres and road allows the motorcyclist to travel around the corner at greater speed?

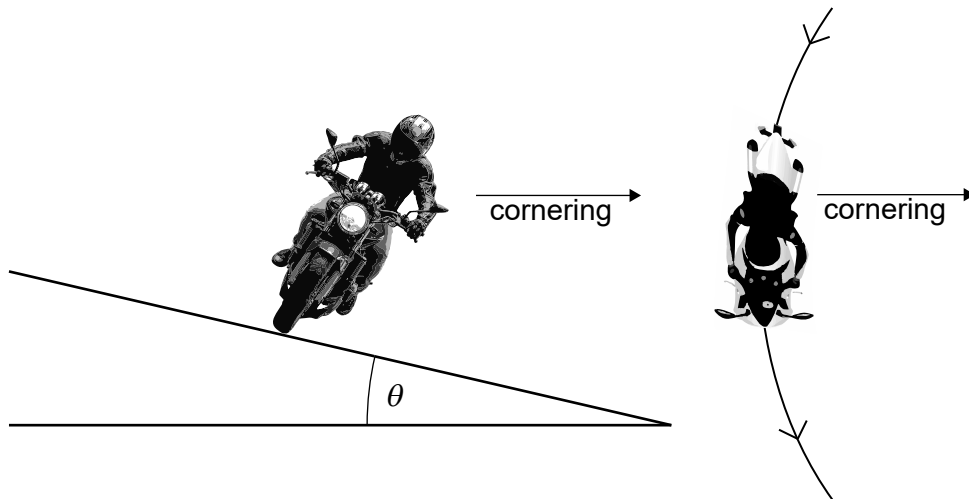

	Banking angle θ	Coefficient of friction μ
A.	increase	increase
B.	increase	decrease
C.	decrease	increase
D.	decrease	decrease

Turn over

22. The diagram shows the emission spectrum of an atom.

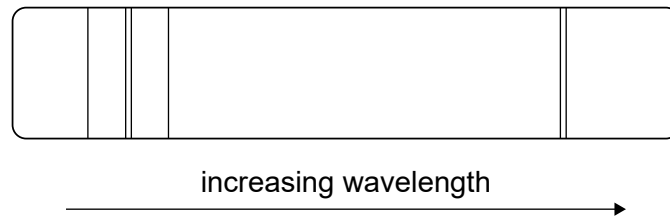

Which of the following atomic energy level models can produce this spectrum?

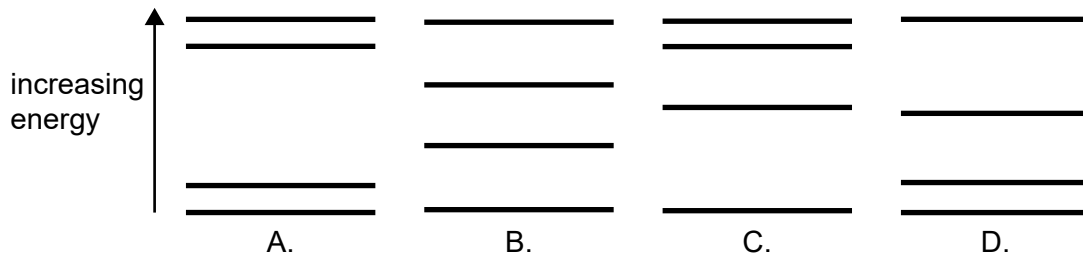

23. The carbon isotope $^{14}_6\text{C}$ is radioactive. It decays according to the equation

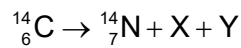

What are X and Y?

	X	Y
A.	$^0_{-1}\beta$	ν_e
B.	$^0_{-1}\beta$	$\bar{\nu}_e$
C.	$^0_1\beta$	ν_e
D.	$^0_1\beta$	$\bar{\nu}_e$

24. The rest mass of the helium isotope ^3_2He is m .

Which expression gives the binding energy per nucleon for ^3_2He ?

- A. $\frac{(2m_p + m_n + m)c^2}{3}$
- B. $\frac{(2m_p + m_n - m)c^2}{3}$
- C. $(2m_p + m_n + m)c^2$
- D. $(2m_p + m_n - m)c^2$

25. Most power stations rely on a turbine and a generator to produce electrical energy. Which power station works on a different principle?
- A. Nuclear
 - B. Solar
 - C. Fossil fuel
 - D. Wind

26. A beaker containing 1 kg of water at room temperature is heated on a 400 W hot plate. The specific heat capacity of water is $4200 \text{ J kg}^{-1} \text{ K}^{-1}$.

The temperature of the water increases until it reaches a constant value. It is then removed from the hot plate.

What will be the initial rate of change of temperature?

- A. 10 K s^{-1}
- B. 1 K s^{-1}
- C. 0.1 K s^{-1}
- D. 0.01 K s^{-1}

Turn over

27. In science, models are extensively used to study real life situations.

A person X on the beach wants to reach a person Y in the sea in the shortest possible time. The speed of person X on land is different from the speed of person X in the water. Which physical phenomenon will best model the path with the least time?

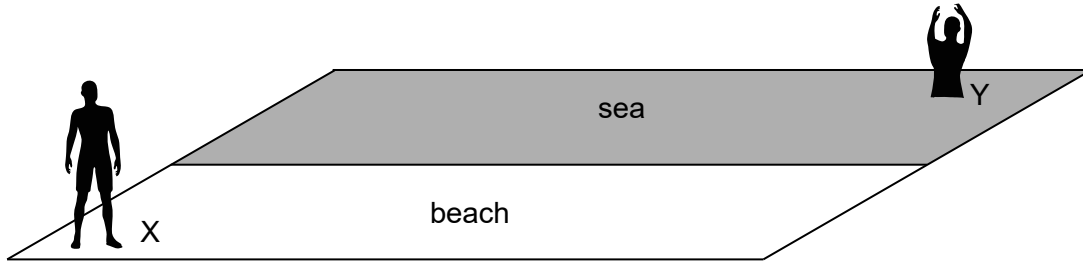

- A. Conservation of momentum
 - B. Diffraction
 - C. Flow of charge in a conductor
 - D. Refraction
28. The four pendulums shown have been cut from the same uniform sheet of board. They are attached to the ceiling with strings of equal length.

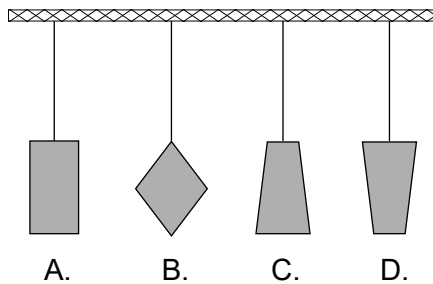

Which pendulum has the shortest period?

29. In a Young's double-slit experiment, the distance between fringes is too small to be observed.

What change would increase the distance between fringes?

- A. Increasing the frequency of light
- B. Increasing the distance between slits
- C. Increasing the distance from the slits to the screen
- D. Increasing the distance between light source and slits

30. The headlights of a car emit light of wavelength 400 nm and are separated by 1.2 m. The headlights are viewed by an observer whose eye has an aperture of 4.0 mm. The observer can just distinguish the headlights as separate images. What is the distance between the observer and the headlights?

- A. 8 km
- B. 10 km
- C. 15 km
- D. 20 km

31. A transparent liquid film of refractive index 1.5 coats the outside of a glass lens of higher refractive index. The liquid film is used to eliminate reflection from the lens at wavelength λ in air.

What is the minimum thickness of the liquid film coating and the phase change at the liquid–glass interface?

	Coating thickness	Phase change
A.	$\frac{\lambda}{3}$	0
B.	$\frac{\lambda}{3}$	π
C.	$\frac{\lambda}{6}$	0
D.	$\frac{\lambda}{6}$	π

32. A negative charge Q is to be moved within an electric field E, to equidistant points from its position, as shown.

Which path requires the most work done?

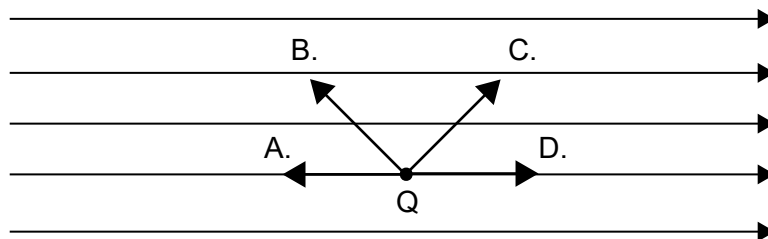

Turn over

33. The escape velocity for an object at the surface of the Earth is v_{esc} . The diameter of the Moon is 4 times smaller than that of the Earth and the mass of the Moon is 81 times smaller than that of the Earth. What is the escape velocity of the object on the Moon?

A. $\frac{2}{81}v_{\text{esc}}$

B. $\frac{4}{81}v_{\text{esc}}$

C. $\frac{2}{9}v_{\text{esc}}$

D. $\frac{4}{9}v_{\text{esc}}$

34. A satellite in a circular orbit around the Earth needs to reduce its orbital radius.

What is the work done by the satellite rocket engine and the change in kinetic energy resulting from this shift in orbital height?

	Work done by the satellite rocket engine	Kinetic energy
A.	positive	increase
B.	positive	decrease
C.	negative	increase
D.	negative	decrease

35. The graph below shows the variation with time of the magnetic flux through a coil.

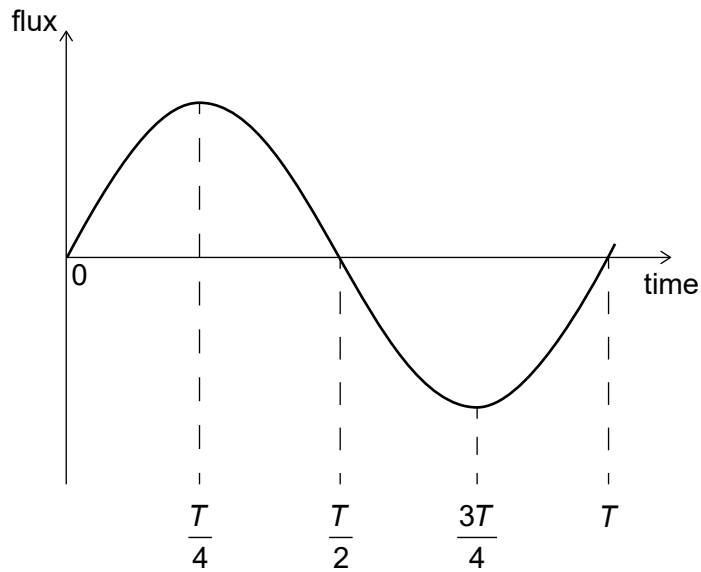

Which of the following gives three times for which the magnitude of the induced emf is a maximum?

- A. $0, \frac{T}{4}, \frac{T}{2}$
 - B. $0, \frac{T}{2}, T$
 - C. $0, \frac{T}{4}, T$
 - D. $\frac{T}{4}, \frac{T}{2}, \frac{3T}{4}$
36. Two capacitors of $3\ \mu\text{F}$ and $6\ \mu\text{F}$ are connected in series and charged using a 9V battery.
What charge is stored on each capacitor?

	Charge stored on $3\ \mu\text{F}$ capacitor	Charge stored on $6\ \mu\text{F}$ capacitor
A.	$18\ \mu\text{C}$	$18\ \mu\text{C}$
B.	$81\ \mu\text{C}$	$81\ \mu\text{C}$
C.	$18\ \mu\text{C}$	$81\ \mu\text{C}$
D.	$81\ \mu\text{C}$	$18\ \mu\text{C}$

Turn over

37. The circuit diagram shows a capacitor that is charged by the battery after the switch is connected to terminal X. The cell has emf V and internal resistance r . After the switch is connected to terminal Y the capacitor discharges through the resistor of resistance R .

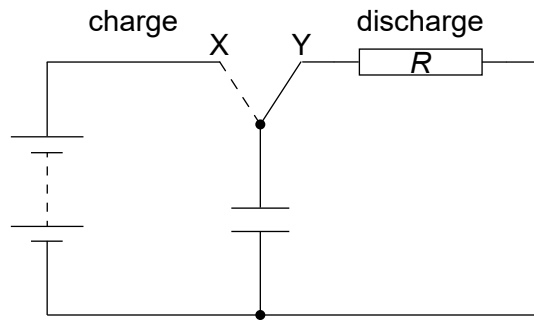

What is the nature of the current and magnitude of the initial current in the resistor after the switch is connected to terminal Y?

	Nature of current	Magnitude of initial current
A.	increasing	$\frac{V}{R}$
B.	increasing	$\frac{V}{R+r}$
C.	decreasing	$\frac{V}{R}$
D.	decreasing	$\frac{V}{R+r}$

38. A metallic surface is first irradiated with infrared radiation and photoelectrons are emitted from the surface. The infrared radiation is replaced by ultraviolet radiation of the same intensity.

What will be the change in the kinetic energy of the photoelectrons and the rate at which they are ejected?

	Kinetic energy of photoelectrons	Rate of ejected photoelectrons
A.	increase	decrease
B.	decrease	decrease
C.	increase	constant
D.	decrease	constant

39. The half-life of a radioactive nuclide is 8.0 s. The initial activity of a pure sample of the nuclide is 10 000 Bq. What is the approximate activity of the sample after 4.0 s?
- A. 2500 Bq
 - B. 5000 Bq
 - C. 7100 Bq
 - D. 7500 Bq
40. A particle is confined within a nucleus. What is the order of magnitude of the uncertainty in the momentum of the particle?
- A. 10^{-10} N s
 - B. 10^{-15} N s
 - C. 10^{-20} N s
 - D. 10^{-25} N s
-